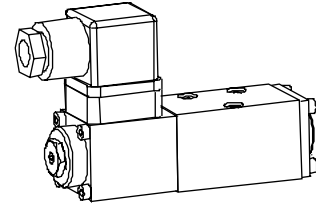

Proportional directional valve

- not pressure compensated
- $Q_{max} = 8 \text{ l/min}$
- $p_{max} = 315 \text{ bar}$

NG3-Mini®

DISCRIPTION

Directly controlled spool valve, actuated by a proportional solenoid, in five chamber design. Wet solenoid in oil. Spool with precisely machined control edges produce a progressive volume flow characteristic similar to proportional flow valves. Reduced pressure drop achieved by optimised flow channels. Precise spool fit, long life. Spool made of hardened steel, valve body made of high quality cast iron suitable for hydraulic valves. Flange type, threaded connection by means of a connecting plate.

FUNCTION

Spool stroke, aperture and volume flow increase proportionally to the increase in the electric current at the proportional solenoid. Proportional directional valves NG3-Mini are not load-compensated. Meter-in, meter-out and symmetrical flow control options available. The optimum spool shape and progressive characteristics curve allow fine motion control. Wandfluh power amplifiers are needed to activate the proportional directional valves (register 1.13).

APPLICATION

Because of the high resolution, high volume flow and low hysteresis, these valves are particularly suitable for demanding tasks. Because the valves are light and compact, Mini-3 proportional valves are particularly suitable for installations where space or weight is a problem. Applications: handling operations, robots, actuators, radar controlled vehicles, tool making and paper production machines, in other words anywhere where very small yet convenient and precise control systems are needed.

CONTENT

GENERAL SPECIFICATIONS	1.10-65/1
HYDRAULIC SPECIFICATIONS	1.10-65/1
ELECTRICAL SPECIFICATIONS	1.10-65/1
TYPE CHARTS/ DESIGNATIONS OF SYMBOLS	1.10-65/2
CONTROL MODE	1.10-65/2
CHARACTERISTICS	1.10-65/2
DIMENSIONS	1.10-65/2
PARTS LIST	1.10-65/2
ACCESSORIES	1.10-65/2

TYPE CODE

Proportional-directional control valve	WDP	F	A03	-	□	□	-	□	-	5	-	□	#	□
Flange														
Nominal size 3-Mini														
Symbol type see chart on page 2														
Control mode														
Symmetrical														
Meter-in														
Meter-out														
Nominal flow at 10 bar pressure drop over 2 metering edges = 5 l/min														
Supply voltage														
12VDC														
24VDC														
Design-Index (Subject to change)														

GENERAL SPECIFICATIONS

Nominal size	NG 3-Mini
Designation	4/2-, 4/3- Proportional-control valve
Construction	Direct operated spool valve
Mounting	Flange, 3 fastening hols for socket headscrews M4x30
Fastening torque	2,8 Nm (qual. 8.8)
Pipe connection	Connection plates, Multi-station flange
Mounting position	subplate, Longitudinal stacking system
Ambient temperature	any
Weight: 1 solenoid-version	-20...+50°C
2 solenoid-version	m = 0,5 kg
	m = 0,6 kg

HYDRAULIC SPECIFICATIONS

Fluid	Mineral oil, other fluid on request
Contamination efficiency	ISO class 16/13
	(Required filtration grade $\beta_{6...10} \geq 75$) refer to data sheet 1.0-50/2
Viscosity range	12 mm ² /s...320 mm ² /s
Fluid temperature	-20...+70°C
Working pressure	p_{max} 315 bar (Connection P, A, B)
Tank pressure	max tank pressure in T
	p_{max} 160 bar
Nominal volume flow	$Q_N = 5 \text{ l/min}$ at 10 bar pressure drop over 2 metering edges
	For values which deviate from the nominal flow Q_N the valve pressure drop Δp can be calculated by following formula:

$$\Delta p = \Delta p_N \left(\frac{Q}{Q_N} \right)^2$$

Q_N = Nominal volume flow
 Q = Effective volume flow
 Δp_N = Nominal pressure drop 10 bar

ELECTRICAL SPECIFICATIONS

Construction	Proportional solenoid, wet pin push type, pressure tight.	
Standard-Nominal voltage	U = 12 VDC	U = 24 VDC
Limiting current	$I_G = 1080 \text{ mA}$	$I_G = 540 \text{ mA}$
Relative duty factor	100% ED (see data sheet 1.1-430)	
Protection class	IP 65 to DIN 40050	
Connection/Power supply	Over device plug connection to ISO 4400/DIN 43650 (2P+E)	
Other electrical specifications	see data sheet 1.1-90 (PI29V)	



Max. volume flow	$Q_{max} = 8 \text{ l/min}$
Min. volume flow	$Q_{min} = 20 \text{ cm}^3/\text{min}$
Leakage volume flow	see characteristic
Resolution	1 mA*
Repeatability	≤ 1 %*
Hysteresis	≤ 2 %*

* by optimal dithersignal

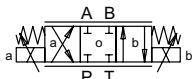
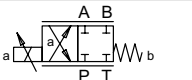
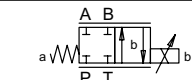
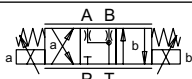
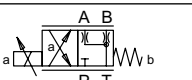
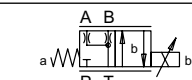
TYPE CHARTS/DESIGNATIONS OF SYMBOLS

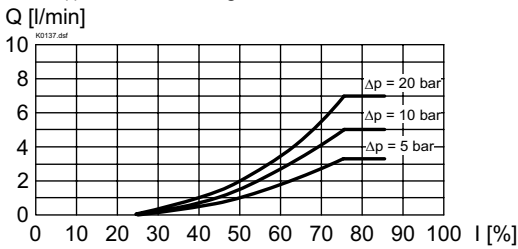
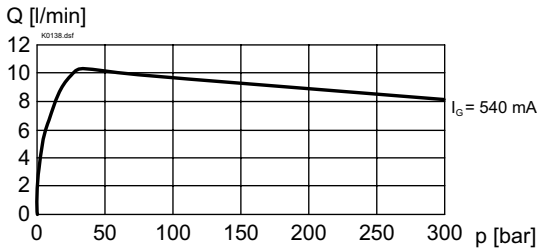
	ACB - $\begin{matrix} S \\ V \\ R \end{matrix}$
	AC1 - $\begin{matrix} S \\ V \\ R \end{matrix}$
	CB2 - $\begin{matrix} S \\ V \\ R \end{matrix}$
	ADB - v
	AD1 - v
	DB2 - v

CHARACTERISTICS oil viscosity $\nu = 30 \text{ mm}^2/\text{s}$
 $Q = f(I)$ Volume flow-signal-characteristics

 $Q = f(p)$ Volume flow-pressure-characteristics

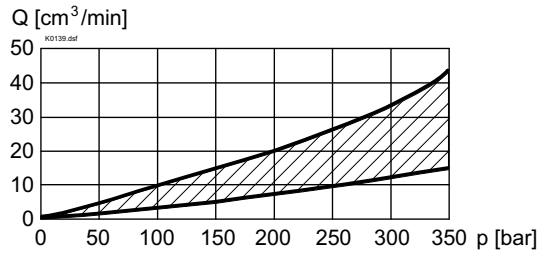
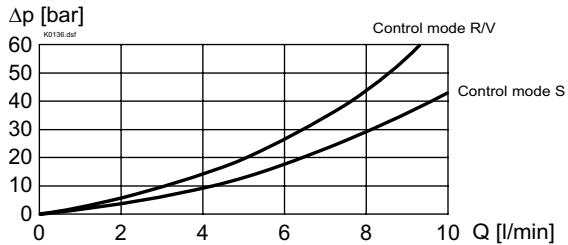
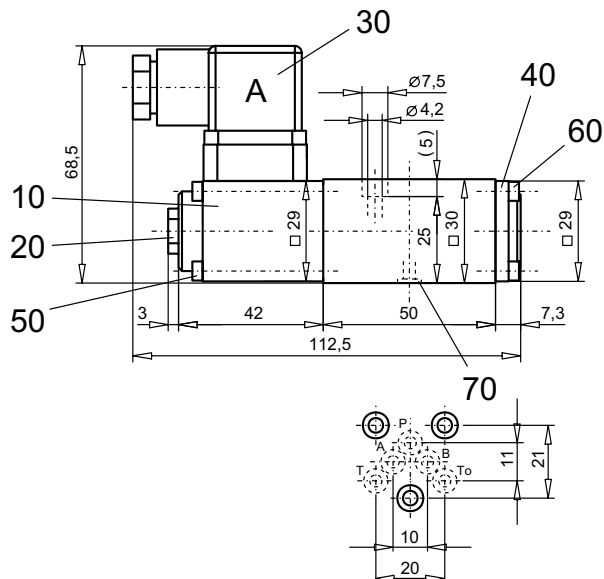
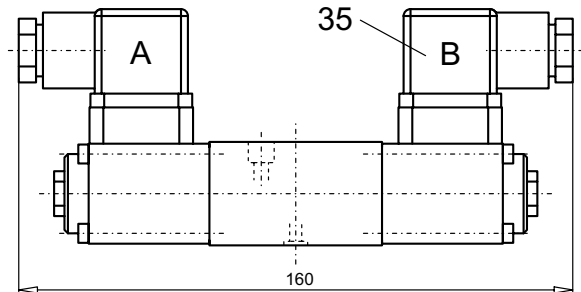
CONTROL MODE

Symmetrical	S	
Meter-in	V	
Meter-out	R	

 $Q_L = f(p)$ Leakage-characteristics

 $\Delta p = f(Q)$ Pressure loss/flow-characteristics over 2 metering edges

DIMENSIONS

PARTS LIST

Position	Article	Description
10	256.2452 256.2416	Proportional solenoid PI29V-G24 Proportional solenoid PI29V-G12
20	253.8000	Plug with integrated manual override HB4,5
30	219.2001	Plug A (grey)
35	219.2002	Plug B (black)
40	056.4100	Cover
50	246.0140	Socket head cap screw M3x40 DIN 912
60	246.0108	Socket head cap screw M3x8 DIN 912
70	160.2045	O-ring ID 4,50x1,5

ACCESSORIES

 Sub-plates Register 1.9
 Proportional-amplifier Register 1.13

Technical explanation see data sheet 1.0-100E