

2 WAY (2/2) Y-BODY VALVE

Stainless



Stainless Steel with Polymer Actuator

US 5502

Description (standard valve)

Flow direction: fixed
Mounting position: optional

Flow fluid range

Fluid temperature: -10 °C up to max. +180 °C
Ambient temperature: -10 °C up to max. +60 °C
Material body: Stainless steel (1.4581)
Seat seal: PTFE
Internal parts: Sandvik 1802
Seal packing: PTFE
FPM self-adjustable

Pilot fluid range

Pilot fluid: neutral gaseous fluids
Fluid temperature : max. +60 °C
Material body: Polyamid 66 with glass fibre 30%
Seat seals : NBR (Perbunan)
Internal parts: Brass (2.0402), 1.4404, 1.4310, 1.8159, 1.1200



Features

- Easy rebuilding into »normally open« or »double-acting« without tools
- Optical position indicator is standard
- Damped closing (Valves closes against flow direction)
- Suitable for contaminated flow fluid
- Suitable for vacuum up to max. 90%
- Reversed flow direction optional
- High flow rate
- With or without mounted pilot valve
- Option pressure actuated by external liquid fluid

Symbol

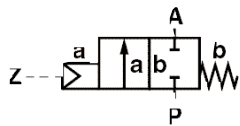

Ordering information

To order, quote model number from table overleaf, e.g. 84 522 00.0000 for a G 1/2 valve without pilot valve.

Characteristic data See page 2 valve and solenoid informations.

Characteristic data

Valves

Part Number ¹	Nominal Diameter (mm)	Port size	Pilot pressure		Operating pressure *		kv-value † (Base m ³ /h)	Weight ** (kg)
			min.	max. (bar)	min	max (bar)		
84 522 00.0000 84 532 00.0000	15	G 1/2 1/2" NPT	3,5	10	0	16,0 (40)	4,80	1,4
84 523 00.0000 84 533 00.0000	20	G 3/4 3/4" NPT	3,5	10	0	10,0 (16)	10,00	1,5
84 524 00.0000 84 534 00.0000	25	G 1 1" NPT	3,5	10	0	10,0	14,00	1,8
84 525 00.0000 84 535 00.0000	32	G 1 1/4 1 1/4" NPT	3,5	10	0	7,0	23,00	2,4
84 526 00.0000 84 536 00.0000	40	G 1 1/2 1 1/2" NPT	3,5	10	0	4,5	30,00	2,7
84 527 00.0000 84 537 00.0000	50	G 2 2" NPT	3,5	10	0	3,0	37,00	3,9

¹ note: 0000 without pilot valve
0164 with pilot valve for DC
0165 with pilot valve for AC

State voltage [V] and frequency [Hz]

* with gaseous and liquid fluids up to 600 mm²/s (cSt)

** without pilot valve

† C_V-value (US) ² kv-value x 1,2

Notes for 3/2-way pilot valve

Material body brass 2.0402
Pilot fluid temperature max. +60 °C
Pilot pressure: p_{max} = 8 bar
Standard voltages: 24 V 1, 24 V 3; 230 V 3

Data for 3/2-way pilot valve

Technical data see publication D107901
Design acc. to VDE 0580
Voltage range ±10%
Duty cycle (ED) 100%
Protection class to EN 60529 IP 65 (formerly DIN 40050)
Socket acc. to DIN 43650

Notes for 3/2-way pilot valve hole pattern NAMUR

Material body aluminium elox
Pilot fluid temperature -10 °C bis +60 °C
Pilot pressure p_{max} = 10 bar
Standard voltages 24 V 1, 24 V 3, 230 V 3
Design acc. to VDE 0580
Voltage range ±10%
Duty cycle (ED) 100%
Protection class to EN 60529 IP 65 (formerly DIN 40050)
Socket acc. to DIN 43650

Data for 3/2-way pilot valve hole pattern NAMUR

Technical data see publication 7503035.XX.XX.XXXX
Design acc. to VDE 0580
Voltage range ±10%
Duty cycle (ED) 100%
Protection class to EN 60529 IP 65 (formerly DIN 40050)
Socket acc. to DIN 43650

Options

available at extra cost

XX XXX **01.XXXX** Normally open, closes with pilot pressure and opens with spring force (pilot pressure 1 – 10 bar)

XX XXX **08.XXXX** Double acting; 4/2 or 5/2-way-pilot valve required

XX XXX **22.XXXX** Higher operating pressure

XX XXX **23.XXXX** Double electrical position indicator

XX XXX **50.XXXX** NAMUR interface plate

On Request several seals: NBR, FPM, EPDM
stroke limiter
silencer
electrical position indicator with proximity switch
DIN or ISO welded ends

Mounting accessories

NAMUR

Interface plate NAMUR hole pattern for retrofit,
(part number 12 565 66) consist of:

1x NAMUR interface plate
2x Adapter screw
2x O-ring

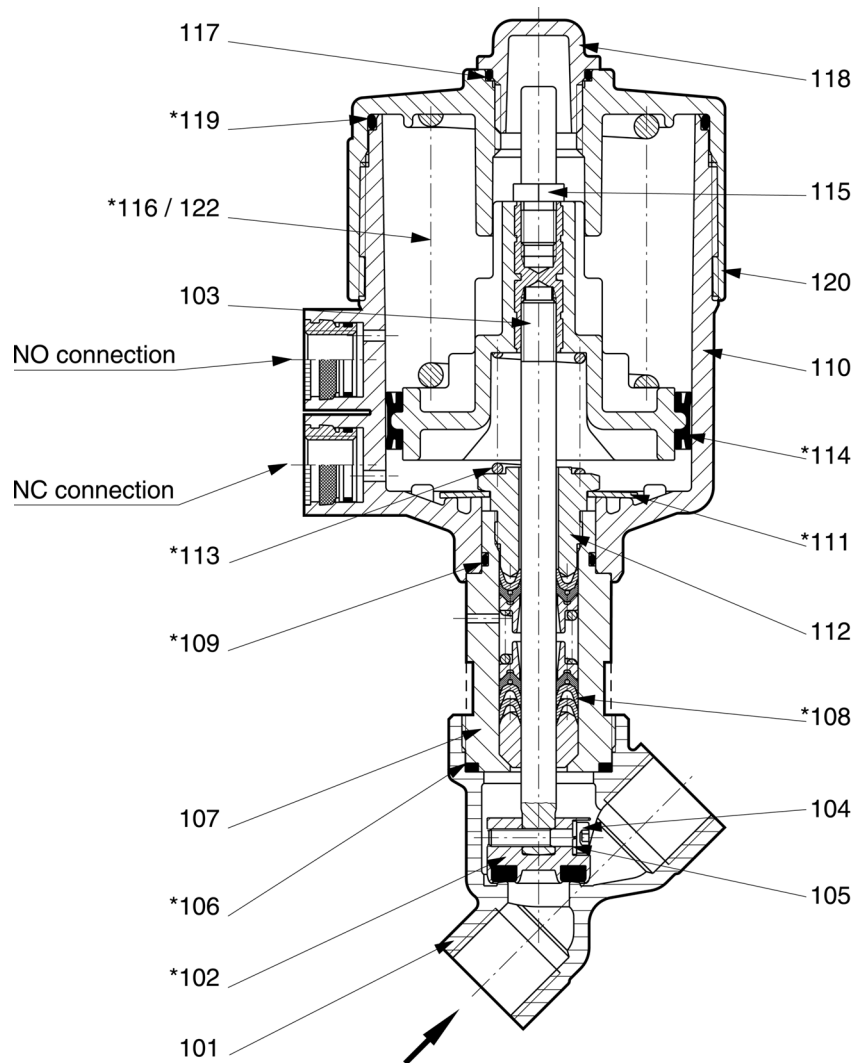

- 101 Valve body
- * 102 Valve plate
- 103 Valve spindle, complete
- 104 Cheese head cap screw
- 105 Spring washer
- * 106 Seal ring
- 107 Screw piece
- * 108 Seal packing
- * 109 O-ring
- 110 Control head housing cover, bottom part
- * 111 Cup spring
- 112 Screw piece
- * 113 Pressure spring

- * 114 Cylinder packing
- 115 Signal pin
- * 116 Pressure spring
- 117 O-ring
- 118 Cover cap
- * 119 O-ring
- 120 Control head housing cover
- * 122 Pressure spring

* These individual parts form a complete wearing unit.
 When ordering spare parts please state Cat no and series no.

General Dimensions

Actuator may be rotated 360°

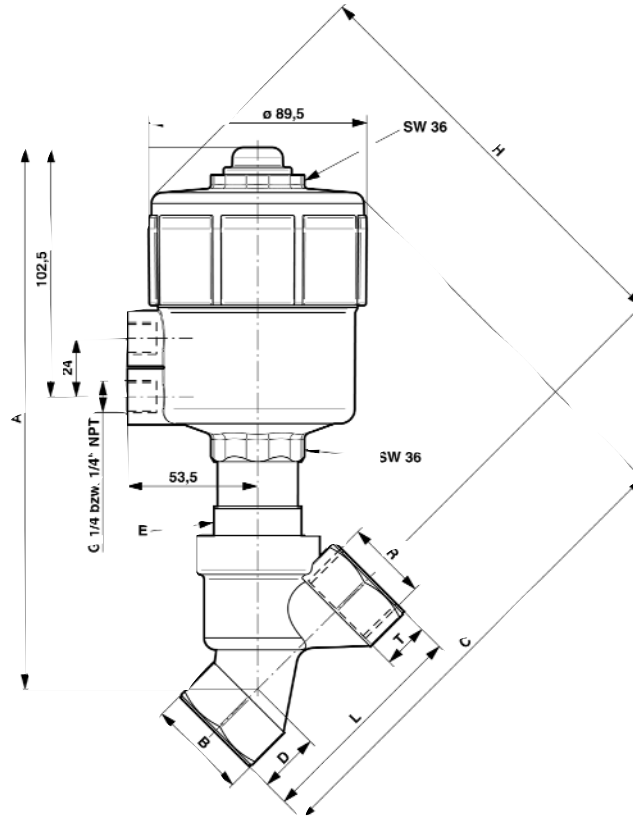

Part Number	A	B	C	D	E	H	L	R	T
84 522 00.0000	204,5	SW 27	183,0	18,5	SW 30	164,0	65	G 1/2	15,0
84 532 00.0000								1/2" NPT	13,0
84 523 00.0000	213,5	SW 32	189,0	21,0	SW 36	168,0	75	G 3/4	16,5
84 533 00.0000								3/4" NPT	14,0
84 524 00.0000	221,5	SW 41	199,0	25,0	SW 36	174,0	90	G 1	19,0
84 534 00.0000								1" NPT	16,5
84 525 00.0000	236,5	SW 50	212,5	28,5	SW 41	184,5	110	G 1 1/4	21,5
84 535 00.0000								1 1/4" NPT	17,0
84 526 00.0000	238,5	SW 55	217,0	31,0	SW 41	186,0	120	G 1 1/2	21,5
84 536 00.0000								1 1/2" NPT	17,0
84 527 00.0000	250,5	SW 70	234,5	40,0	SW 41	194,5	150	G 2	26,0
84 537 00.0000								2" NPT	17,5

EU Manufacturer's Declaration

as defined in EU Machinery Guideline 89/392/EEC, Appendix II B

We hereby declare that the pressure actuated valves were developed and designed using the following harmonised standards:

EN 292 Machine Safety

EN 983 Pneumatic Systems

EN 60204-1 Electrical Equipment for Machinery

Note

These pressure actuated valves are intended for fitting in a machine. They must not be commissioned until it has been established that the machine as a whole conforms to the EU guideline.

Note on EU guideline

The valves shall be provided with an electrical circuit which ensures the limits of the harmonised standards EN 50081-1 and EN 50082-1 are observed, and hence the requirements of the Electromagnetic Compatibility Guideline (89/336/EEC) satisfied.

HERION USA INC. • 176 Thorn Hill Road • Warrendale • PA 15086

Phone: 724.776.5577 Fax: 724.776.0310

email:sales@herionusa.com

07/2001